

Schaltplan

Schnellkühler / Schockfroster **SKF 5 GN 1/1 PLUS**

[Art. 433000102]



Cliente / Customer :		Commissa :	13847 - 400000007543
C.A.P. / Post code :		Schema Elettrico :	13847 del 09.06.2020
Via / Street :		Cod. Progetto :	Modello Plus Ai - EU
Città / City :		Descrizione :	QE NORTECH PLUS 1x230+T Ai - CS-TW
Telefono / Phone :		Numero Fogli: 10	Cod. Art. Cliente : 400000007543
Fax :		Indice Rev.: 1 Rev. Index :	Cod. Art. Tecso : 13847
E-Mail :		Data Rev. : 09/06/2020 Rev. date :	

Note di revisione / Rev. Notes :

(*) Deve essere predisposto un Limitatore di Corrente " a monte" dell'alimentazione del Quadro Elettrico, che garantisca l'intervento per il valore di Corrente Icc indicato

(*) There must be a current limiter before the supply of the electrical panel, which guarantees the operation to the value of Icc current indicated

Disegnatore:	Tecso srl	Tensione Esercizio: Working Voltage	1x230V+T
Drawer:		Tensione Ausiliari: Auxiliaries Voltage	12V-24V
Verificatore:	Tecso srl	Tensione Segnali: Signals Voltage	12V-24V
Verifier:		Frequenza: Frequency:	50-60Hz
Approvatore:	NORMANN Srl	Corrente nominale: Nominal current: A (F.P.=	Corrente Icc (*) : Icc Current (*) :
Approver:		Potenza totale: Total power: kW
Responsabile Progetto:	NORMANN Srl	Grado di protezione: Protection level:	IP20
Project manager:			

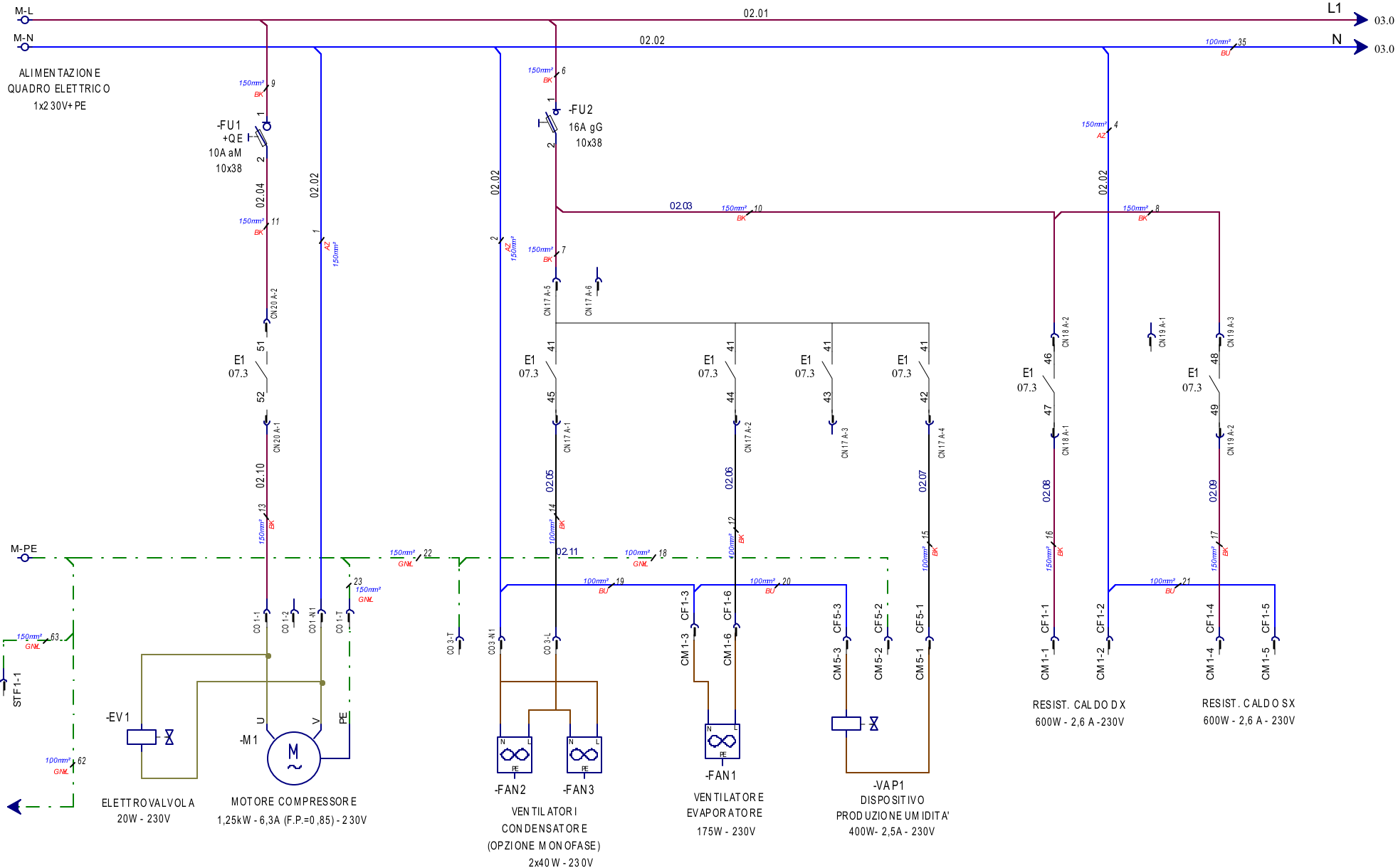

1	09/06/2020		
REV	DATA / DATE	FRMA/SIGN.	MODIFICA / CHANGE

PROGETTO / PROJECT: Modello Plus Ai - EU		
CLIENTE / CUSTOMER:		
COMMESSA / COMMITTED: 13847 - 40 000 000 07543		
TITOLO / TITLE: Sezione Alimentazione		
DIS. / DRAW.: Tecso srl	DATA / DATE:	LOC.:

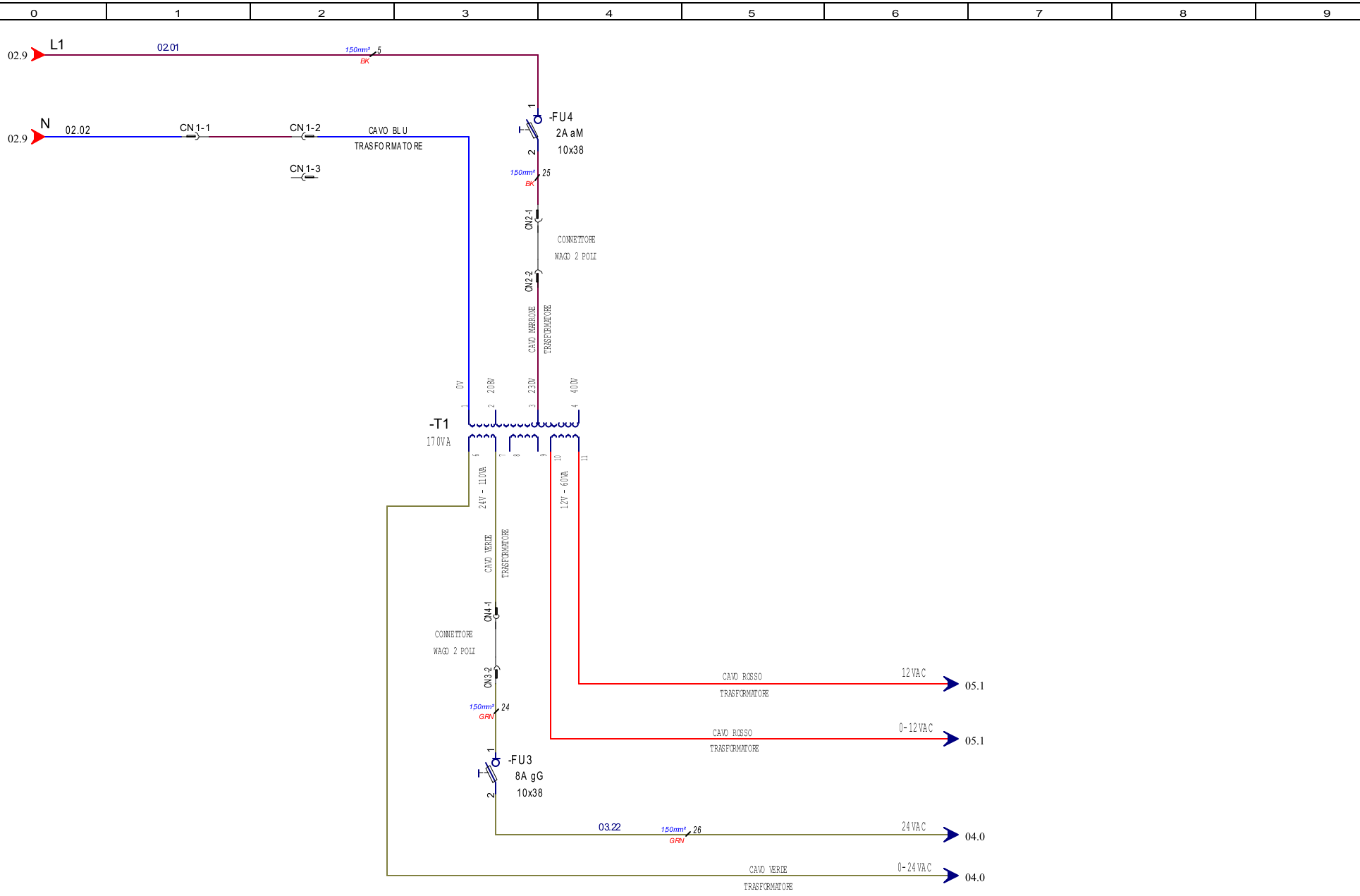

1	09/06/2020		
REV.	DATA / DATE	FRMA/SIGN.	MODIFICA / CHANGE

PROGETTO / PROJECT: Modello Plus Ai - EU		
CLIENTE / CUSTOMER:		
COMMESSA / COMMITTED: 13847 - 400000007543		
TITOLO / TITLE: Sezione Servizi 12VAC		
DIS. / DRAW.: Tecso srl	DATA / DATE:	LOC.: QE

03.6 24 VAC

03.6 0-24 VAC

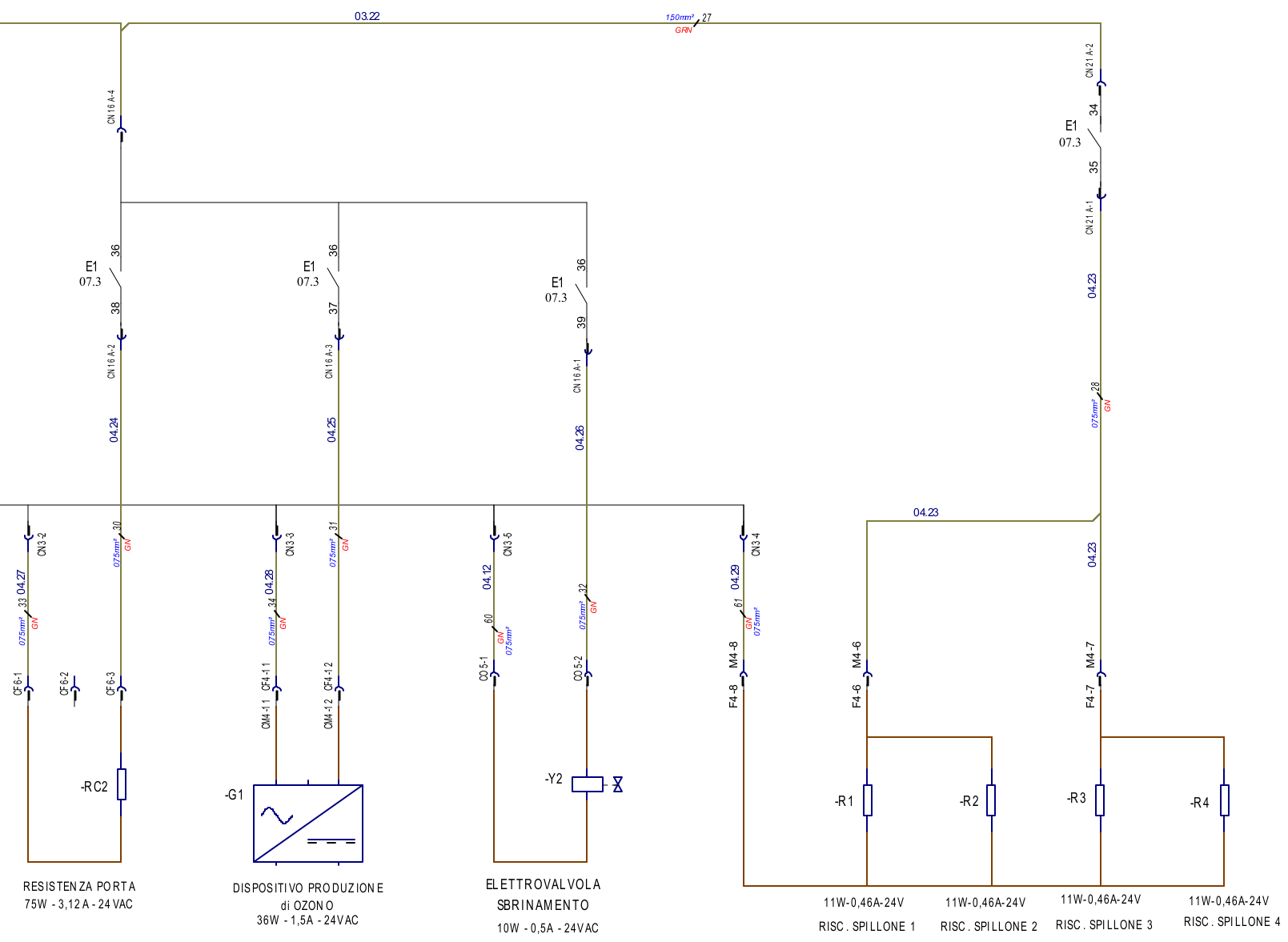

1	09/06/2020		
REV.	DATA / DATE	FRMA/SIGN.	MODIFICA / CHANGE

PROGETTO / PROJECT: Modello Plus Ai - EU		
CLIENTE / CUSTOMER:		
COMMESSA / COMMITTED: 13847 - 40 000 000 07543		
TITOLO / TITLE: Sezione Servizi 24VAC		
DIS. / DRAW.: Tecso srl	DATA / DATE:	LOC.: QE

-E1

SCHEDA CONTROLLO ECS - Mod. 0140000-0 - INGRESSI ANALOGICI & ALIMENTAZIONE

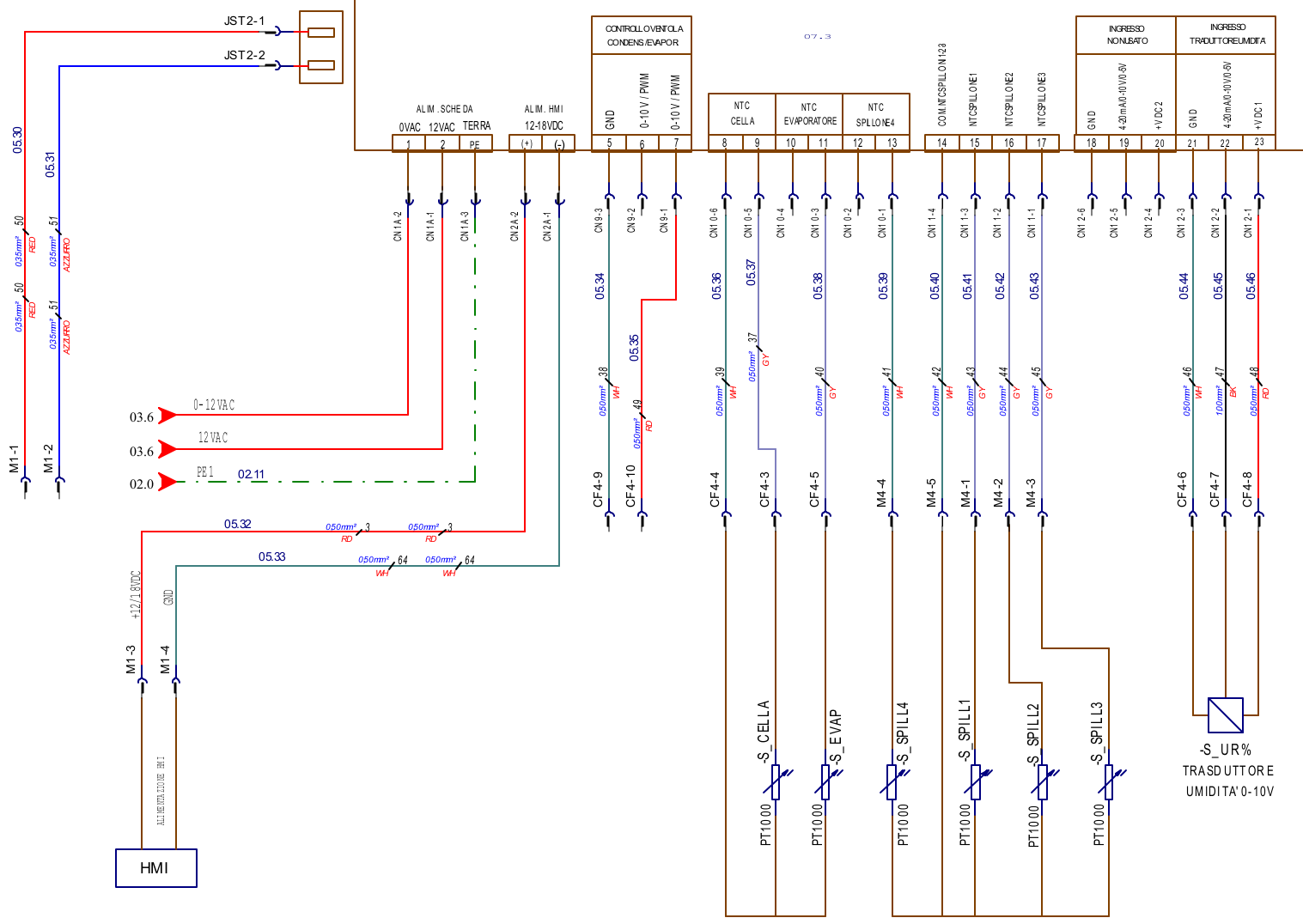

1	09/06/2020	RRMA/SIGN.	MODIFICA / CHANGE

PROGETTO / PROJECT:	Modello Plus Ai - EU
CLIENTE / CUSTOMER:	
COMMESSA / COMMITTED:	13847 - 400000007543
TITOLO / TITLE:	Scheda Controllo : INGR. ANALOGICI e ALIMENTAZIONE
DIS. / DRAW.:	Tecso srl
DATA / DATE:	
LOC.:	QE

-E1

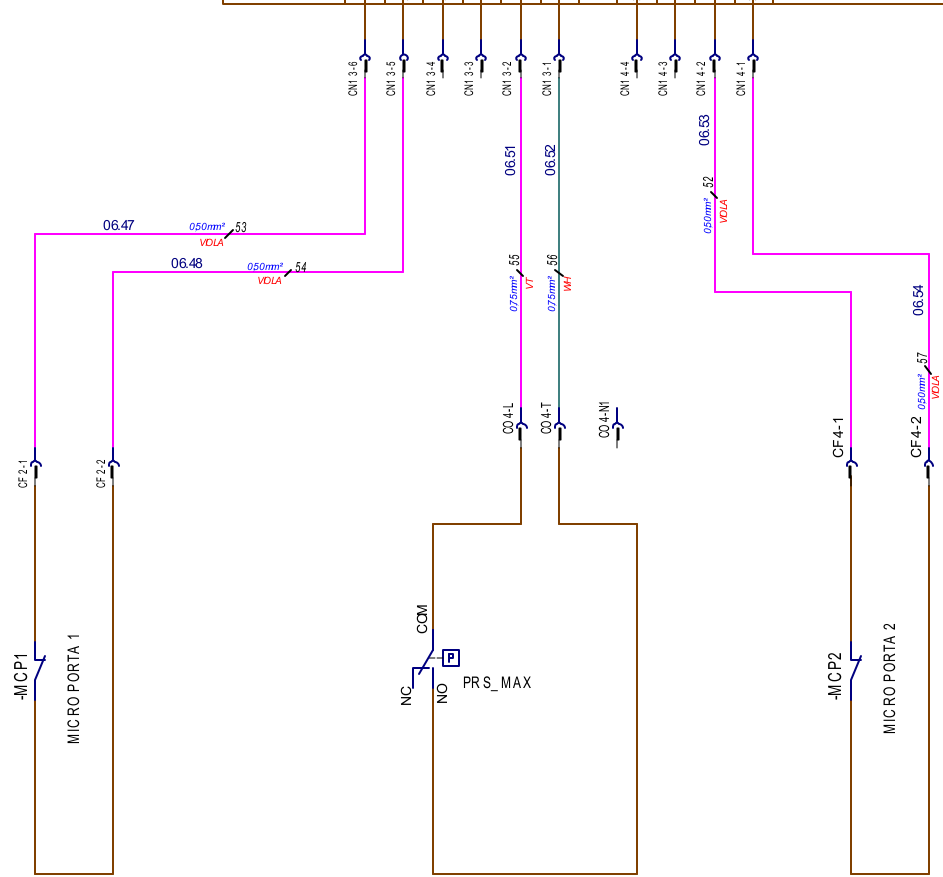
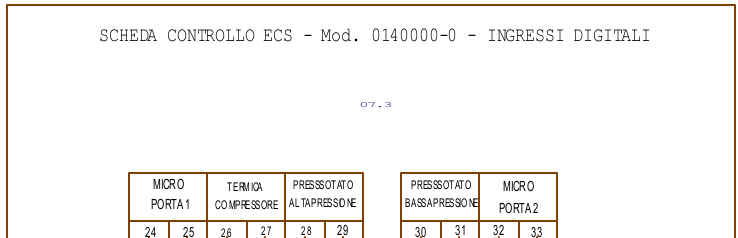

SEGNALE ALTA PRESSIONE

1	09/06/2020		
REV.	DATA / DATE	FRMA/SIGN.	MODIFICA / CHANGE

PROGETTO / PROJECT:	Modello Plus Ai - EU
CLIENTE / CUSTOMER:	
COMMESSA / COMMITTED:	13847 - 400000007543
TITOLO / TITLE:	Scheda Controllo : INGRESSI DIGITALI
DIS. / DRAW.:	Tecso srl
DATA / DATE:	
LOC.:	QE

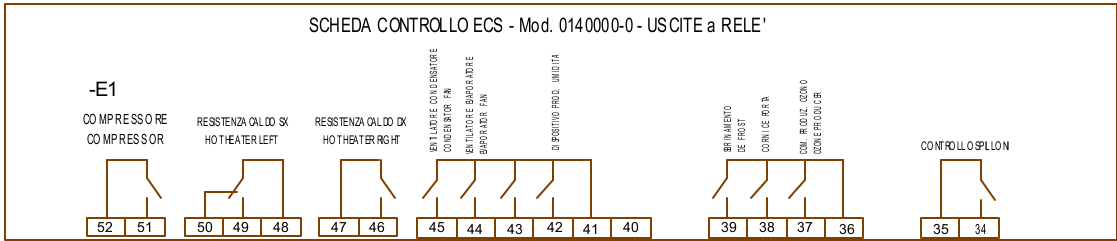

- 51-52 - -
- 48-49 - -
- 48-50 - -
- 46-47 - -
- 41-42 - -
- 41-43 - -
- 41-44 - -
- 41-45 - -
- 36-37 - -
- 36-38 - -
- 36-39 - -
- 34-35 - -
- 24-25 06.4
- 21-22 05.5

1	09/06/2020		
REV.	DATA / DATE	FRMA/SIGN.	MODIFICA / CHANGE

PROGETTO / PROJECT: Modello Plus Ai - EU		
CLIENTE / CUSTOMER:		
COMMESSA / COMMITTED: 13847 - 400000007543		
TITOLO / TITLE: Scheda Controllo : USCITE DIGITALI		
DIS. / DRAW.: Tecso srl	DATA / DATE:	LOC.: QE

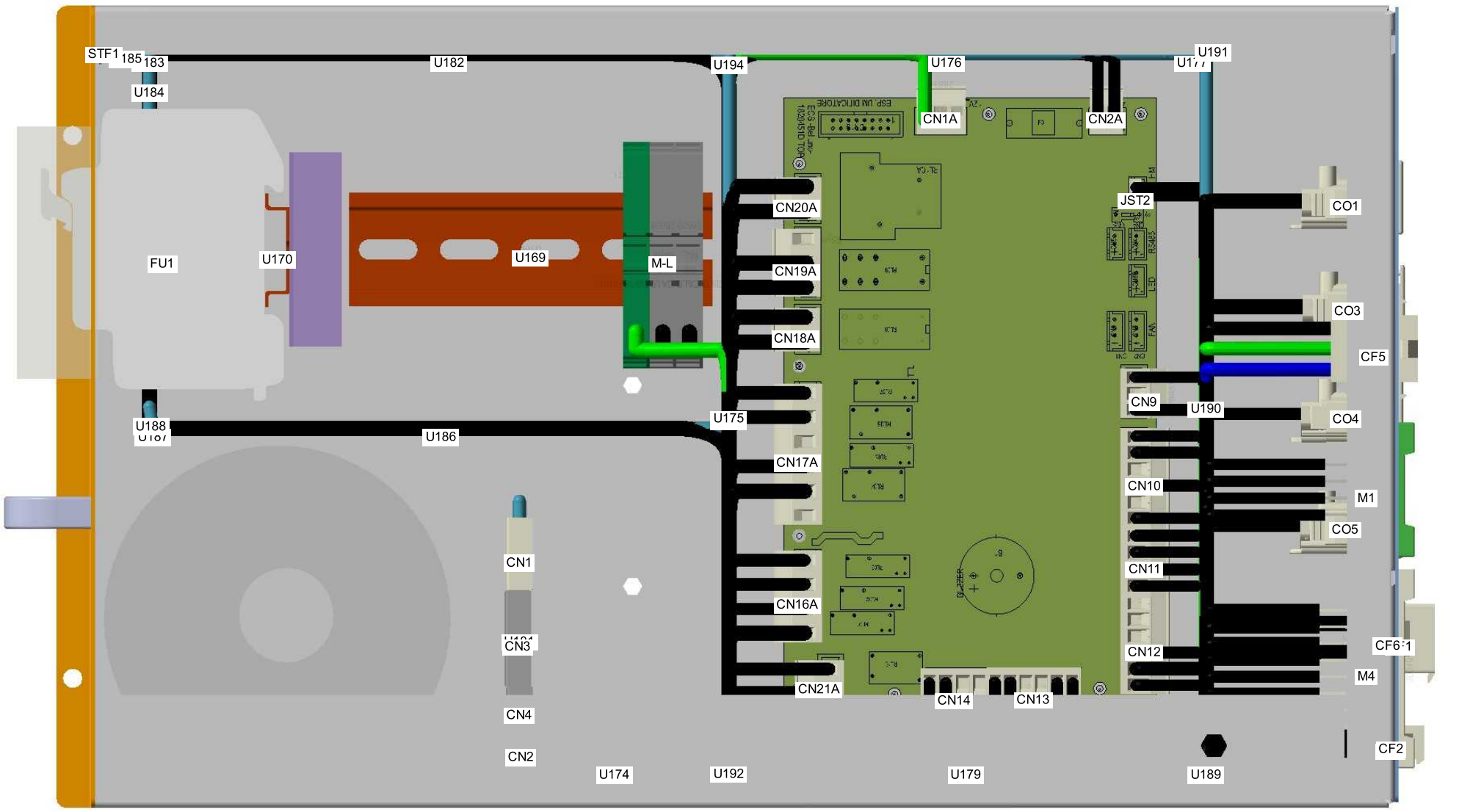

1	09/06/2020		
REV.	DATA / DATE	FRMA/SIGN.	MODIFICA / CHANGE

PROGETTO / PROJECT:	Modello Plus Ai - EU
CLIENTE / CUSTOMER:	
COMMESSA / COMMITTED:	13847 - 40 000 000 07543
TITOLO / TITLE:	Lay Out 1
DIS. / DRAW.:	Tecso srl
DATA / DATE:	
LOC.:	QE

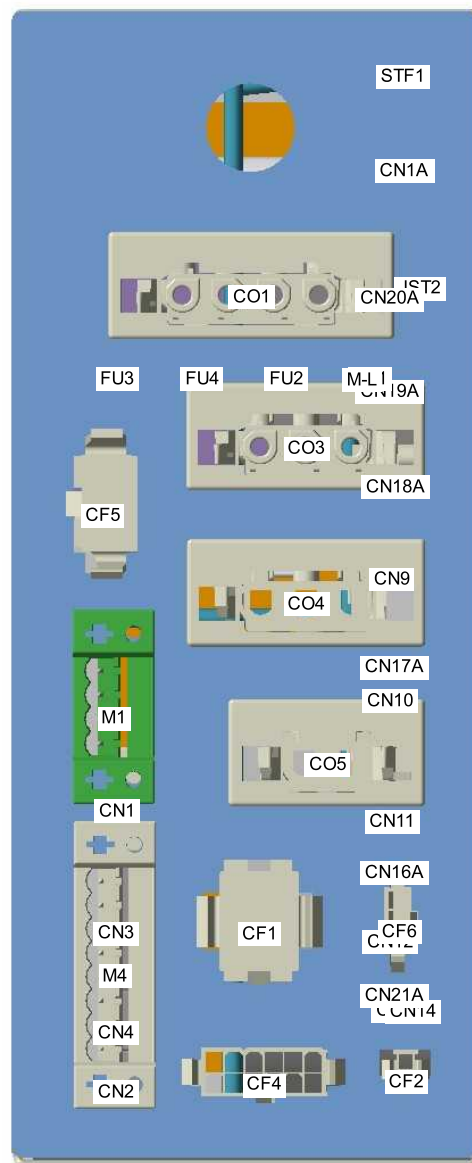
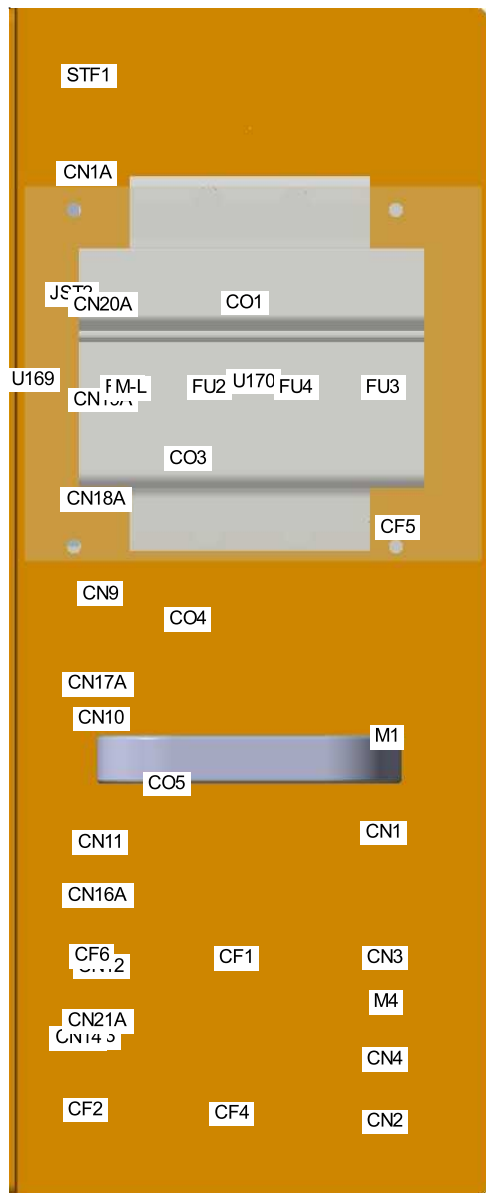

1	09/06/2020		
REV.	DATA	FIRMA	MODIFICA



PROGETTO: Modello Plus Ai - EU		
CLIENTE:		
COMMESSA: 13847 - 40 000 000 07543		
TITOLO: Lay Out 2		
DIS.: Tecso srl	DATA:	LOC.: QE

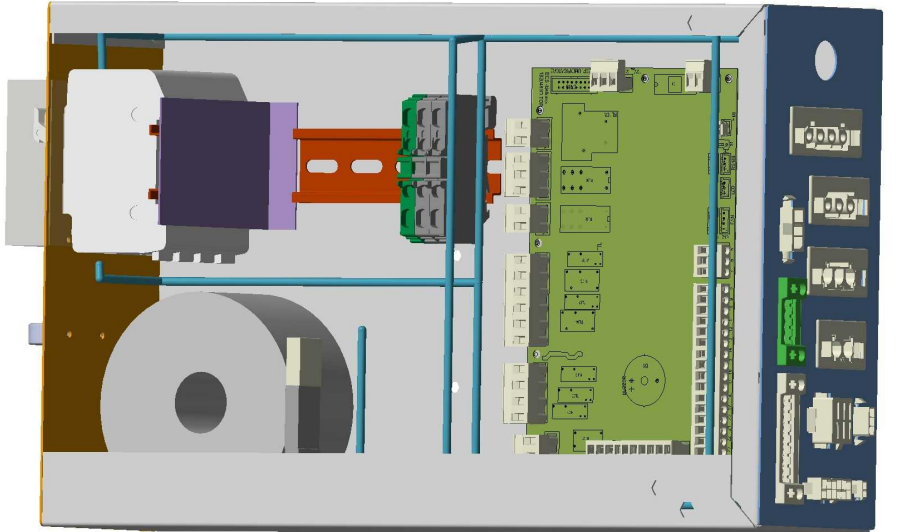
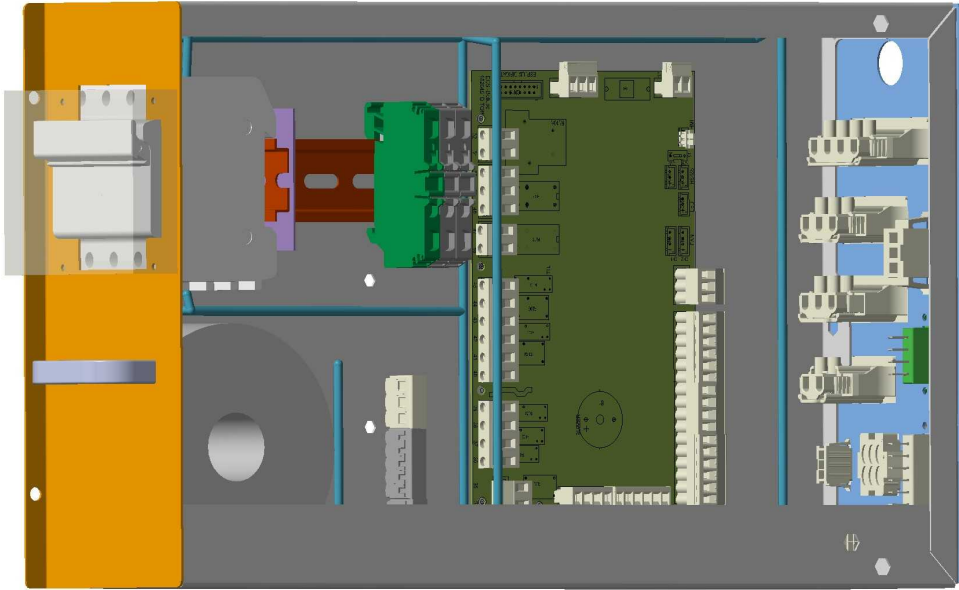

REV.	DATA / DATE	FRMA/SIGN.	MODIFICA / CHANGE

PROGETTO / PROJECT: Modello Plus Ai - EU CLIENTE / CUSTOMER: COMMESSA / COMMITTED: 13847 - 40 000 000 07543 TITOLO / TITLE: Lay Out 3		
DIS. / DRAW.: Tecso srl	DATA / DATE:	LOC.: QE

NordCap GmbH & Co. KG
Thalendorststraße 15
28307 Bremen
Hauptsitz (Service, Finanzen & Personal, Lager, IT, Marketing)

Telefon: +49 421 48557-0
Telefax: +49 421 488650
E-Mail: bremen@nordcap.de

Die NordCap Verkaufsniederlassungen in Deutschland:

Nord: Hamburg • Ost: Berlin • Süd: Ingelheim • West: Erkrath

